

Dane County Rezone Petition

Application Date	Petition Number
10/22/2021	DCPREZ-2021-11778
Public Hearing Date	
12/28/2021	

OWNER INFORMATION	AGENT INFORMATION
-------------------	-------------------

OWNER NAME TIMOTHY AND CHERYL KRAUSSE	PHONE (with Area Code) (608) 290-5677	AGENT NAME COMBS AND ASSOCIATES	PHONE (with Area Code) (608) 752-0575
BILLING ADDRESS (Number & Street) 11747 DALLMAN RD		ADDRESS (Number & Street) 109 W. MILWAUKEE ST.	
(City, State, Zip) EDGERTON, WI 53534		(City, State, Zip) Janesville, WI 53548	
E-MAIL ADDRESS timkrausse@yahoo.com		E-MAIL ADDRESS rmcombs@combssurvey.com	

ADDRESS/LOCATION 1		ADDRESS/LOCATION 2		ADDRESS/LOCATION 3	
ADDRESS OR LOCATION OF REZONE		ADDRESS OR LOCATION OF REZONE		ADDRESS OR LOCATION OF REZONE	
117 County Hwy N					
TOWNSHIP ALBION	SECTION 32	TOWNSHIP	SECTION	TOWNSHIP	SECTION
PARCEL NUMBERS INVOLVED		PARCEL NUMBERS INVOLVED		PARCEL NUMBERS INVOLVED	
0512-322-8500-5					

REASON FOR REZONE

SEPARATING EXISTING RESIDENCE FROM FARMLAND

FROM DISTRICT:	TO DISTRICT:	ACRES
FP-35 Farmland Preservation District	RR-2 Rural Residential District	2.0

C.S.M REQUIRED? <input checked="" type="checkbox"/> Yes <input type="checkbox"/> No Applicant Initials _____	PLAT REQUIRED? <input type="checkbox"/> Yes <input checked="" type="checkbox"/> No Applicant Initials _____	DEED RESTRICTION REQUIRED? <input type="checkbox"/> Yes <input checked="" type="checkbox"/> No Applicant Initials _____	INSPECTOR'S INITIALS RWL1	SIGNATURE:(Owner or Agent) PRINT NAME: DATE:
--	---	---	----------------------------------	--



Legend

-  Wetland
-  Floodplain

Significant Soils

- Class 1
- Class 2



0 50 100 200 Feet

Petition 11778
TIMOTHY AND CHERYL
KRAUSSE

EDGERTON STORAGE UNITS MINI STORAGE BUILDING 2 & 3

69 US Hwy 51 Edgerton, WI 53534

DRAWING INDEX:	
SP-1	SITE PLAN, DRAWING INDEX
SP-1	CONCRETE RETAINING WALL DETAILS
SP-1	BRICK WALL DETAILS
SP-1	WALL SECTION
SP-1	ELEVATIONS
PROJECT DESCRIPTION:	
PROPOSED GROUP S-1 MINI-STORAGE BUILDING, WISCONSIN, 2015 IRC BUILDING CODE.	
BUILDING INFORMATION:	
TYPE USE:	MINI STORAGE
CONSTRUCTION TYPE:	5.027 S.I.
BUILDING FOOTPRINT:	5,627 S.I.
NO. OF FLOORS:	1
OCCUPANT GROUP:	S-1
SPRINKLED:	NONE
SOIL BEARING:	3,000 PSF ASSUMED

VERIFY ALL CONDITIONS AND DIMENSIONS ON THE JOB AND NOTIFY THE DESIGN ALLIANCE IMMEDIATELY OF ANY DISCREPANCIES PRIOR TO START.

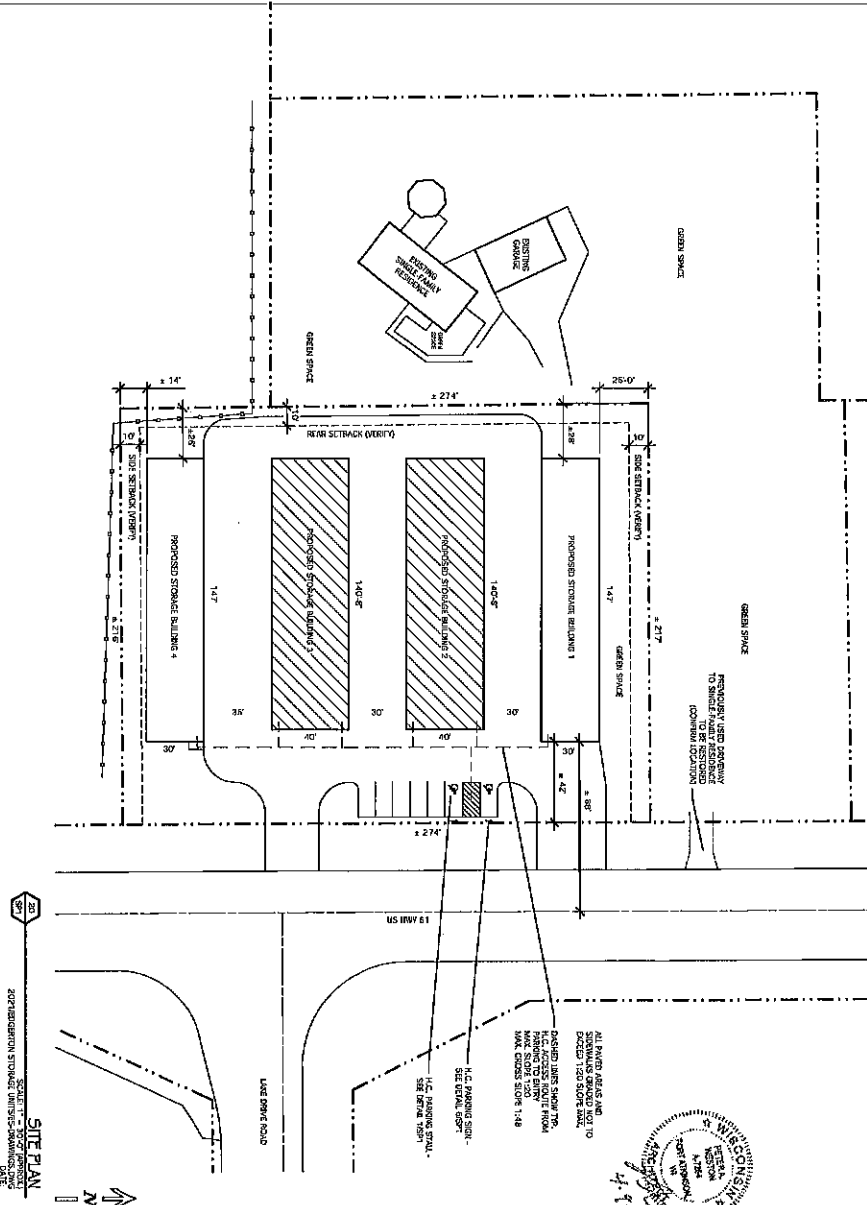
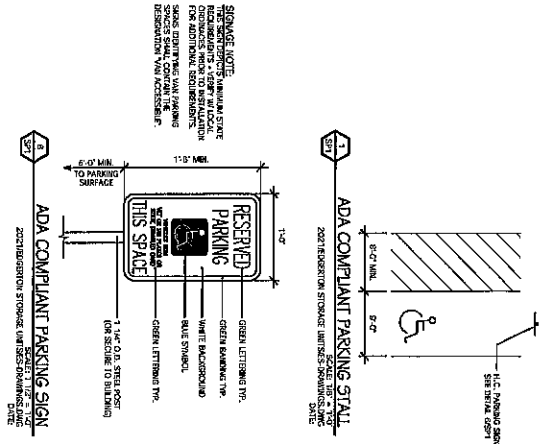

 1005 Madison Avenue Fort Atkinson, WI (202) 885-9404	EDGERTON STORAGE UNITS MINI STORAGE BUILDING 2 & 3 69 US Hwy 51 Edgerton, WI 53534			
	DRAWING NAMES SITE PLAN DRAWING INDEX PARKING DETAILS			
	REVISIONS <table border="1"> <tr> <th>NO.</th> <th>DESCRIPTION</th> </tr> <tr> <td> </td> <td> </td> </tr> </table>	NO.	DESCRIPTION	
NO.	DESCRIPTION			

PROJECT DATA
DATE: 08/02/2021
DRAWN BY: JK
CHECKED BY: P.W.
SHEET NO. SP-1